



This manual contains safety information that, if ignored, could endanger life or cause serious injury to people and property.



Keep the controller protected from sun and water.
Avoid splashing with water.



Depending on the chosen configuration, the main screen of the controller may appear different and some functions may not be present.

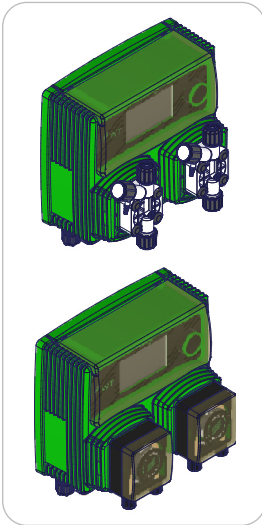

Operation manual for "WT" Tower



Read carefully!



ENGLISH version

R5-06-26

EC RULES
EC RULES (EC STANDARDS)
NORMAS DE LA CE



Low Voltage Directive }
Low Voltage Directive } **2014/35/EU**
Directiva de baja tensión }

EMC Electromagnetic Compatibility Directive }
EMC electromagnetic compatibility directive } **2014/30/EU**
EMC directiva de compatibilidad electromagnética }

GENERAL SAFETY INFORMATION

Danger. During an emergency of any kind within the environment where the pump unit is installed, you must immediately cut power to the system and disconnect the controller from the power outlet!

If particularly aggressive chemical materials are used, the regulations regarding the use and storage of these substances must be strictly followed!

If you install the controller outside the European Community please follow the local safety regulations !

The manufacturer cannot be held responsible for damage to persons or property used by improper installation or misuse !

Warning. Install the controller so that it is easily accessible whenever a maintenance work! Never obstruct the place where the controller is located!

The controller must be slaved to an external control system. In the event of a water shortage, dosing must be stopped.

Service and maintenance of the controller and all its accessories must be carried out always by qualified personnel!

Always carefully empty and flush pipes that have been used with particularly aggressive chemical materials! Wear the most appropriate safety equipment for the maintenance procedure!

Always carefully read the chemical characteristics of the product to be dosed!

All installation and maintenance operations must always be carried out when the controller is not connected to the power supply!

Failure to activate the Min / Max alarm and the maximum dosage alarm can lead to a dangerous overdose!

2. Introduction

WT is a comprehensive, advanced solution for controlling and dosing chemicals (biocide & inhibitor) within cooling towers. The system allows for the accurate monitoring and regulation of water conductivity—a fundamental parameter for maintaining plant efficiency and preventing scaling and corrosion. Depending on the version, it features two peristaltic or electromagnetic metering pumps for dosing the biocide and inhibitor. These chemicals are essential for water treatment and disinfection, as they prevent the proliferation of bacteria and algae. The advanced chemical activation feature ensures safe and optimized delivery based on programmed cycles or detected conditions. The system also integrates a corrosion and scale inhibitor dosing function, ensuring continuous protection for metal surfaces and piping. Additionally, WT manages automatic water blowdown based on the measured conductivity value, preventing the accumulation of dissolved solids and ensuring an optimal chemical balance within the cooling water circuit.

The system can be fully controlled remotely.

Conductivity reading: 0 - 10000 μS (ECD)
0 - 3000 μS , 0 / 30000 μS (ECDIND)

Temperature reading: 0 to 100°C

Information is shown on a large LCD display. Using the innovative ENCODER, the controller can be easily programmed, connected to the network, remotely controlled even via APP. WT is housed in an IP65 plastic box (IP54 model with peristaltic).

Inputs:

- Conductivity Probe
- Inlet water meter
- Level 1 and 2
- Flow sensor
- Standby

Outputs:

- Alarm (free contact relay)
- MODBUS RTU Port
- Pump 1 and 2
- Vac out 1 5A (solenoid valve/other)

3. ENCODER

Positioned in the upper right corner is the encoder for controlling the controller. This knob can be rotated in either direction to scroll through menus and pressed to select the highlighted item.

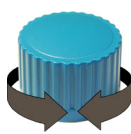

| Calibration μS | | |
|---------------------------|---------------------|--------------|
| P1 | $\mu\text{S PROBE}$ | Calib At |
| P2 | 0000 | 10.00 |
| TE | | |
| 2nd Point | | ESC OK |

Turn the knob to scroll through the menus



| Calibration μS | | |
|---------------------------|---------------------|--------------|
| P1 | $\mu\text{S PROBE}$ | Calib At |
| P2 | 0000 | 10.00 |
| TE | | |
| 2nd Point | | ESC OK |

Press the knob to select the highlighted item

4.1 WT CONNECTIONS

Disconnect the controller from the power supply to make connections to the selected probes and/or outputs according to the figure below. **CAUTION: Connections must be made by experienced and qualified personnel only after disconnecting the controller from the main power supply.**

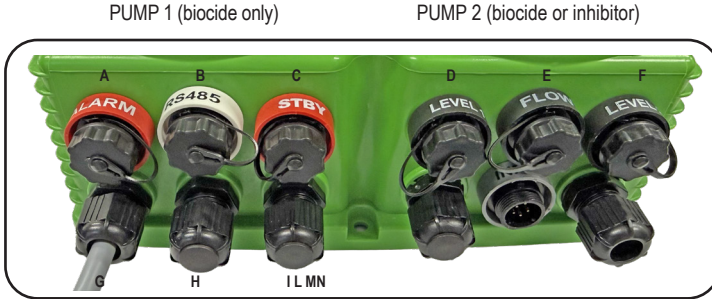

Use rubber plugs to protect unused connections
Warning: connections should only be made by qualified and trained personnel

| NAME | CONTACT | PIN CONNECTOR | |
|-------------------------------------|---|----------------|---|
| A) Contact Alarm | 1: contact | 2: Contact | |
| B) RS485 | 1: +RS485 | 2: -RS485 | 3: PIN Termination |
| C) Standby | 1: STANDBY signal | 2: GND Standby | |
| D) Biocide Level Pump 1 | 1: contact | 2: Contact | |
| E) Flow Sensor | wired | | |
| F) Level Biocide / Inhibitor Pump 2 | 1: contact | 2: Contact | |
| G) Controller power supply: | 90/240 VAC 50-60Hz (peristaltic) 230Vac (190 ÷ 270) 50/60Hz 115Vac (90 ÷ 135) 50/60Hz (solenoid) | | |
| H) Output 90/240 VAC 50-60Hz | Discharge (BLEED) MAX LOAD 5A | | |
| M) WaterMeter | 2: Signal WM 3: GND WM | |  |
| N) Wired Conductivity Probe | (ECD / ECDIND probe) with / without temperature compensation | | |

5. About evaporative towers.

What is a cooling tower?

A cooling tower is a heat rejection device that extracts waste heat to the atmosphere by cooling a stream of water to a lower temperature. The type of heat rejection in a cooling tower is called "evaporative" in that it allows a small portion of the water being cooled to evaporate into a moving stream of air to provide significant cooling to the rest of that water stream. The heat from the water stream transferred to the air stream increases the air temperature and relative humidity to 100 percent, and this air is discharged to the atmosphere. Evaporative heat dissipation devices such as cooling towers are commonly used to provide significantly lower water temperatures than can be achieved with "air-cooled" or "dry" air cooling devices such as an automobile radiator, thus achieving more economical and energy-efficient operation of systems that require cooling. Think of times when you have seen something hot cooled rapidly by putting water on it, which evaporates, cooling rapidly, like an overheated car radiator. The cooling potential of a wet surface is much better than a dry one.

Common applications for cooling towers provide chilled water for air conditioning, manufacturing, and power generation. The smallest cooling towers are designed to handle water flows of only a few gallons per minute delivered in pipes as small as those you might see in a residence, while the largest hundreds of thousands of gallons per minute delivered in pipes up to 15 feet (about 5 meters) in diameter on a large power plant.

The generic term "cooling tower" is used to describe both direct (open circuit) and indirect (closed circuit) heat disposal equipment. While most think of a "cooling tower" as a direct-contact discharge device, the indirect cooling tower, sometimes referred to as a "closed-loop cooling tower," is nevertheless also a cooling tower.

An open-loop or direct cooling tower is an enclosed structure with internal means to distribute hot water to it fed over a labyrinth-shaped packing or "fill." The fill provides a greatly expanded air-water interface for air heating and evaporation to take place. The water is cooled as it descends through the fill by gravity while in direct contact with the air passing through it. The cooled water is then collected in a cold water basin below the fill from which it is pumped through the process to absorb more heat. The heated, moist air leaving the backfill is discharged to the atmosphere at a point far enough away from the intakes to prevent it from re-entering the cooling tower.

The fill may consist of several wet surfaces, mainly vertical, over which a thin layer of water extends (film fill), or several layers of horizontal elements that create a cascade of many small droplets that have a large combined area (fill).

A closed-loop or indirect cooling tower involves no direct air contact and the fluid, usually water or a glycol mixture, is cooled. Unlike the open cooling tower, the indirect cooling tower has two separate fluid circuits. One is an external circuit in which water is recirculated outside the second circuit, which is a bundle of pipes (closed coils) that are connected to the process for the hot fluid to be cooled and returned to a closed circuit. Air is drawn through the recirculating water that cascades down the outside of the hot tubes, providing evaporative cooling similar to an open cooling tower. During operation, heat flows from the internal fluid circuit, through the walls of the coil tube, to the external circuit and then from the heating of the air and evaporation of some of the water, into the atmosphere. The operation of indirect cooling towers is thus very similar to the open cooling tower with one exception. The process fluid being cooled is contained in a "closed" circuit and is not directly exposed to the atmosphere or recirculated external water.

In a counterflow cooling tower, air travels upward through the fill or pipe bundles, opposed to the downward movement of water. In a cross-flow cooling tower, air moves horizontally through the fill while water moves downward.

Cooling towers are also characterized by the way air is moved. Mechanical draft cooling towers rely on motor-driven fans to draw or force air through the tower. Natural draft cooling towers take advantage of the buoyancy of exhaust air rising in a tall stack to provide draft. A vented natural draft cooling tower uses a mechanical draft to increase the buoyancy effect. Many early cooling towers relied only on the prevailing wind to generate the draft.

If chilled water is returned from the cooling tower for reuse, water must be added for replacement or replenishment portion of the stream that evaporates. Because evaporation consists of pure water, the concentration of dissolved minerals and other solids in circulating water will tend to increase unless a means of controlling dissolved solids, such as blowdown, is provided. Water is also lost by droplets that are made by exhaust air (drift), but it is usually reduced to a very small amount by installing baffle-shaped devices, called droplet eliminators, to collect the droplets. The amount of make-up must be equal to the total of evaporation, blow-down, drift, and other water losses such as wind spill and leakage to maintain a constant water level.

Some useful terms commonly used in the cooling tower industry:

Drift: water droplets that are expelled from the cooling tower with exhaust air. Drift droplets have the same concentration of impurities as the water entering the tower. Drift velocity is typically reduced by employing baffle-shaped devices, called droplet eliminators, through which air must travel after leaving the tower's fill and spray zones.

Blow-out: Water droplets are blown out of the cooling tower by wind, usually at the air inlet openings. Water can also be lost, in the absence of wind, through splashing or misting. Devices such as windshields, fins, splash guards, and water diverters are used to limit these losses.

Plume: The flow of saturated exhaust air leaving the cooling tower. A plume is visible when water vapor contains condensation in contact with cooler ambient air, such as saturated air in breath mists on a cold day. Under certain conditions, a cooling tower plume may present hazards of fogging or ice in the surroundings. Note that the water evaporated in the cooling process is "pure" water, as opposed to the very small percentage of drift droplets or water blown in from the vents.

Blow down: The part of the circulating water stream that is removed in order to keep the amount of dissolved solids and other impurities at an acceptable level.

Leaching: The loss of wood preservative chemicals from the washing action of water flowing through a wood structure cooling tower.

Noise: Sound energy emitted from a cooling tower and heard (recorded) at a given distance and direction. Sound is generated by the impact of falling water, movement of air by fans, fan blades moving in the structure, motors, gearboxes, or drive belts.

6. "WT" main screen.

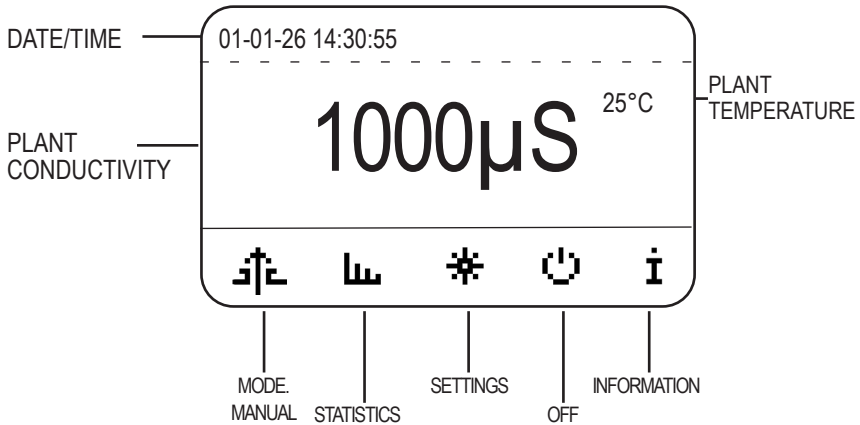

Background color display information (RGB version only): GREEN: Normal operation mode | WHITE: Standby or OFF | RED: Alarm (information status) | YELLOW: Warning (check controller, e.g., active delay time).

WT Operating Status Messages.

| Message displayed | Explanation | Requested action |
|---------------------|---|--|
| "INHIBITOR" | INHIBITOR mode in progress. Corrosion inhibitor dosing in progress. | No action required |
| "BLEED hh:mm" | BLEED hh:mm mode in progress. Restoring conductivity values | No action required |
| "PRE BLEED" | PRE-BLEED mode in progress. Purging water before biocide dosing. | No action required |
| "PRE BIOCID 1 or 2" | PRE BIOCID 1 or 2 in progress. Biocide activator dosing in progress. | No action required |
| "BIOCID 1 or 2" | BIOCID 1 or 2 in progress. Hazardous organism suppression in progress. | No action required |
| "LOCKOUT 1 or 2" | LOCKOUT 1 or 2 in progress. Blocked purge mode after biocide dosing. | No action required |
| "ALARM" | ALARM | Check the alarm by turning the knob on the main screen until "Status Alarm" is displayed Once the alarm status is resolved, the controller will resume interrupted activities. |
| "BLEED TIMEOUT" | Pre-purge activity timeout. | Check biocide menu 1 or 2 |

7. "WT" manual mode.



MANUAL MENU

Out Manager

- Biocide
- Inhibitor / Biocide 2
- Out Bleed
- Out Alarm

<- Set Out Manager

The Manual Menu allows manual and timed activation of the instrument's main outputs, independently from the automatic control and dosing logics. Through the OUT MANAGER option, it is possible to select:

- "DISABLED" – Manual functions disabled
- "MANUAL" – Manual functions enabled
- "STOP" – Outputs activity interrupted
- "UNLOADING" (Biocide and Inhibitor only) – Pump priming reversal; pumps will rotate in the opposite direction for unloading

This function is intended exclusively for:

test and verification operations, maintenance operations, controlled start-ups, extraordinary operating situations.

During manual activation, the selected output remains active for the set time, regardless of measurement conditions, scheduled programs or automatic algorithms.

BIOCIDE (Manual Biocide Dosing).

Enables manual activation of the biocide dosing pump.

Settable time: 1 to 99 minutes

Function: direct start of biocide dosing for the selected time

Typical use:

dosing line priming

pump and circuit check

Overtime dosing not linked to automatic programs

During manual dosing, weekly or daily programming logic is not applied.

INHIBITOR (Manual Dosing Inhibitor).

Allows manual activation of the inhibitor dosing pump.

Settable time: 1 to 99 minutes

Function: forced dosing of the inhibitor for the selected time

Typical use:

initial filling of the circuit

testing of the dosing system

manual integration of treatment

Dosing occurs independently of the automatic logic of association to bleed, time or volume.

7. "WT" manual mode.



OUT BLEED (Manual Bleed).

Allows manual activation of the bleed output (solenoid valve).

Settable time: 1 to 99 minutes

Function: forced opening of the bleed for the selected time

Typical use:

flushing the system

verification of correct operation of the solenoid valve

manual purge during startup or maintenance

At the end of the set time, the output is automatically turned off.

OUT ALARM (Manual Alarm Output).

Allows manual activation of the relay alarm output.

Settable time: 1 to 99 minutes

Function: manual energization of the alarm relay

Typical use:

wiring test

Testing of connected devices (sirens, beacons, external systems)

The output is automatically deactivated when the set time expires. Manual activations do not change configuration parameters or automatic programs. At the end of the set time, the controller automatically returns to normal operation mode. **Prolonged or improper use of manual functions may impair proper water treatment.**



SAFETY WARNING - MANUAL CONTROL FUNCTIONS (MANUAL MENU)



Manual control functions allow temporary activation of the controller outputs in derogation of automatic control logic.

During manual activation of the purge, biocide dosing, inhibitor dosing and alarm output outputs:

process measurements (conductivity, temperature, flow status) are not used for control;
automatic programs and control sequences are not executed;
chemical treatment optimization and protection functions are not guaranteed;
operating conditions not in accordance with the plant design parameters may occur.

Improper use of manual control functions can result in:

uncontrolled dosages of chemicals;
abnormal water consumption;
operation of the system outside the intended conditions;
risk of damage to connected equipment.

Manual control functions should be used only by qualified personnel, in accordance with applicable safety regulations, and only for testing, maintenance or extraordinary operations. At the end of the set time, the output is automatically turned off and the controller resumes standard automatic operation.

USER'S RESPONSIBILITY NOTE

The user is responsible for ensuring that the activation of the manual control functions is done under conditions that are safe for the system, connected equipment, and the operating environment.

Before using the Manual Menu, the user must ensure that:

the system is suitable for receiving manual commands;
the devices connected to the outlets (solenoid valves, metering pumps, annunciators) are properly installed and operational;
external safety devices provided by the plant are present and operational.

The controller is not designed to automatically prevent the consequences of improper use of manual control functions.

The manufacturer assumes no liability for damage to persons, property, or equipment resulting from:

use not in accordance with the instructions in the manual;
use of the manual functions as an ordinary mode of operation;
failure to check the operating conditions of the system.

Compliance with applicable regulations and plant safety procedures remains the responsibility of the user.

8. “WT” statistics



| STATISTICS | |
|------------|---------|
| WM | 00112 L |
| BIO1 | 00234 L |
| INH | 00343 L |
| BIO2 | 00343 L |

Statistics Menu enables the display and management of cumulative counters related to the volumes of water and chemicals dosed by the controller. The values displayed represent incremental totals and are intended for: consumption monitoring, operational audits, maintenance activities, and plant control. The meters do not directly affect automatic regulation and dosing logic.

WM (Water Meter).

Displays the total volume of water passed through the water meter connected to the WATER METER input of the controller.

Unit of measurement: liters

Data source: pulse water meter (Water Meter)

Function: cumulative accounting of the volume of water entering the system

The value gradually increases according to the pulses received from the meter and is not automatically reset.

BIO1 (Biocide 1). Displays the total volume of chemical product dosed by Pump 1.

- Unit of measure: Liters
- Associated pump: Pump 1
- Allowed configuration: Biocide

The value represents the cumulative total of product dosed by Pump 1, calculated according to the configured flow rate parameters.

INHIBITOR (Inhibitor). Displays the total volume of chemical product dosed by Pump 2.

- Unit of measure: Liters
- Associated pump: Pump 2
- Allowed configuration: Inhibitor

The displayed value depends on the configuration assigned to Pump 2 and represents the cumulative total of product dosed.

BIO2 (Biocide 2). Displays the total volume of chemical product dosed by Pump 2.

- Unit of measure: Liters
- Associated pump: Pump 2
- Allowed configuration: Biocide

The displayed value depends on the configuration assigned to Pump 2 and represents the cumulative total of product dosed.

Reset operation

The reset operation is irreversible and results in the permanent loss of the accumulated data.

9. "WT" Main Menu

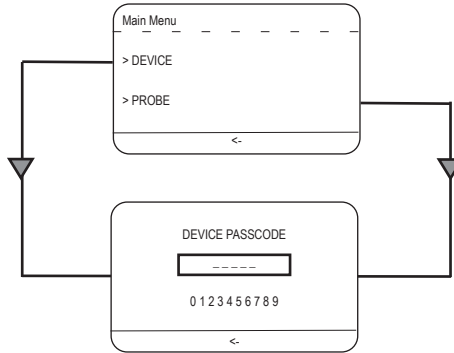

MAIN MENU.

Access to the Main Menu allows advanced configuration of the controller through two main groups of parameters:

DEVICE
PROBE

Access to these functions is protected by a 4-digit numeric password in order to prevent unauthorized changes to operating parameters.

Default password: 0000

Changing the password is available in the DEVICE → SERVICE → PASSWORD menu.

Accessing the Main Menu

Accessing the DEVICE and PROBE menus requires:

1. Select the Main Menu.
2. Enter the 4-digit numeric password.
3. Confirm to enter the selected menu group.

DEVICE MENU

The Device Menu allows configuration of operating modes, safeties, communications and general controller settings.

Once the correct password is entered, the following submenu is displayed:

- Operating Mode
- Alarms and Warnings
- Communication
- Connectivity
- Service
- Settings

9.1 "WT" Main Menu



Device / Operating Mode

Allows configuration of the operating modes of the main functions of the controller.

The available items are:

- Pump 1
- Pump 2
- Bleed
- Water Meter

This menu defines the operational behavior of the dosing pumps and purge function according to the selected configuration.

Device / Alarms and Warnings

Allows management of alarm and warning conditions.

The menu is divided into:

- Inputs / Outputs (Alarms and alerts associated with controller inputs and outputs)
- Other (Other alarms and system alerts)

Device / Communication

Allows configuration of serial communication parameters.

- Modbus RS485
- Modbus ID
- Baud Rate
- Communication format (e.g. 8N1)

The parameters must be consistent with the connected supervisory or control system.

Device / Connectivity

Allows configuration of the following parameters:

- **Network Setup**, Summary of network parameters acquired after Ethernet / WiFi connection. First perform a network scan to detect available networks before connection. DHCP can be set to manual (static) if required.
- **APP Notification**, Enables in-app instrument status notifications.
- **Message**, Configuration of the type of notifications to be sent (via APP and/or email).
- **Email 1 and 2**, Allows entry of up to two email addresses to receive alarm / warning notifications.
- **Scan WiFi Network**, Scans available WiFi networks and allows selection of the preferred network.
- **Firmware Update**, Performs OTA (Over-The-Air) firmware update of the instrument, subject to availability of a new firmware version and active internet connection.

Changes become effective only after saving.

9.2 "WT" Main Menu



Device / Service

Menu reserved for service functions, maintenance and advanced configuration.

Includes the following items:

- Log Setup
- Maintenance
- Password
- Power Delay
- Factory Default

The operations available in this menu can affect the overall behavior of the controller.

Device / Settings

Allows configuration of general interface and system settings.

Includes:

- Language
- Date and Time
- Unit of Measure
- Display for adjusting the brightness and contrast of the screen

Device / Probe

Allows configuration of general probe settings, tau and temperature coefficient.

Includes:

- Calibration uS
- Calibration Temperature
- Correction Factors

The "Correction Factors" menu allows configuration of the signal dynamic filtering and temperature compensation parameters. These parameters directly affect the calculation of the measured value and must be set according to the probe type and application.

9.3 "WT" Main Menu, operating mode pump 1



Device / Operating Mode

Allows configuration of the operating modes of the main functions of the controller.

- Pump 1
- Pump 2
- Bleed
- Water Meter

This menu defines the operating behavior of the metering pumps and bleed function according to the selected configuration.

Preliminary Note - Water Meter Configuration

All features involving the water meter (Water Meter) are operational and give reliable results only if the meter has been previously configured in the Operating Mode → Water Meter menu. Before enabling or using any function based on the water meter, the user must set one of the following parameters correctly: Liters per pulse or Pulses per liter and the required numerical value.

OPERATING MODE → PUMP 1

The PUMP 1 menu allows the complete configuration of Pump 1, dedicated exclusively to biocide dosing. The available settings determine the physical characteristics of the pump, operating mode and dosing parameters.

CAPACITY

Allows the dosing capacity of the pump to be configured according to the type of peristaltic tube installed.

Hose (Peristaltic tube)

Selection of tube size:

- Ø 4.8 × 1.6 mm
- Ø 1.6 × 1.6 mm

The selection must match the tube physically installed on the peristaltic.

Capacity

Defines the maximum rated flow rate of the pump according to the selected pipe:

- Ø 4.8 × 1.6 mm: up to 3.0 L/h
- Ø 1.6 × 1.6 mm: up to 0.45 L/h (450 mL/h)

Inconsistent setting with the installed tube results in dosing errors.

In the electromagnetic version, these two options are:

CC/STROKE

Dosing in milliliters (cc) per stroke (with a capacity of approximately 10 L/h).

Capacity

Pump flow rate, calculated by multiplying the dosage (expressed in milliliters per stroke) by the maximum number of pump strokes (180), relative to 60 minutes of operation.

9.4 "WT" Main Menu, operating mode pump 1



MODE

Allows you to define the operating mode of Pump 1. The available options are:

DISABLED. The pump is disabled and does not perform any dosing operation.

BIOCIDE. The pump operates as a biocide dosing pump.
Selecting this mode enters the Biocide configuration submenu.

BIOCIDE MENU (PUMP 1)

This submenu allows complete configuration of biocide dosing associated with Pump 1. The parameters to be set are:

PBLD TIME (Pre-Bleed Time).

Set the pre-purge time before starting biocide dosing. The pre-bleed function helps to ensure proper hydraulic conditions before dosing.

LCK (Lock Time)

Sets the blocking time following a biocide dosing event.

During the lock period:

- No new biocide dosages are performed;
- Any subsequent trigger events are ignored.

NWEEK (Number of Weeks)

Allows you to select the number of weeks in the programming cycle from 1 to 4.

WEEK 1 / WEEK 2 / WEEK 3 / WEEK 4

Dosing days can be enabled or disabled for each week.

Available days: MON - TUE - WED - THU - FRI - SAT - SUN. Each day can be set ON / OFF.

RPM / FLOW RATE

Allows you to set the operating parameters of the pump during dosing:

- RPM. Number of rotations per minute of the stepper motor.
- Flow Rate (L/h). Resulting dosing rate, variable according to the tube and RPM set.

WM (Water Meter)

Allows biocide dosing to be associated with pulses from the water meter.

- WM DISABLED Dosing is not affected by meter pulses.
- WM ENABLED Dosing is activated when the set number of pulses is reached.

When WM is enabled, it is possible to set:

- Dosing time:
 - Minutes (xx m)
 - Seconds (yy s)
- Number of pulses:
 - Format: 0005 (example)

Example: 05m 30s - 0005

→ the pump doses for 5 minutes and 30 seconds each time 5 pulses are received from the water meter.

Important Operational Note

- Pump 1 can only be configured as a Biocide.
- All parameters must be consistent with plant and product characteristics chemical used.
- Incorrect settings may cause noncompliant dosages.

9.5 "WT" Main Menu, operating mode pump 2



OPERATING MODE → PUMP 2

CAPACITY

Allows the dosing capacity of the pump to be configured according to the type of peristaltic tube installed.

Hose (Peristaltic tube)

Selection of tube size:

- Ø 4.8 × 1.6 mm
- Ø 1.6 × 1.6 mm

The selection must match the tube physically installed on the peristaltic.

Capacity

Defines the maximum rated flow rate of the pump according to the selected pipe:

- Ø 4.8 × 1.6 mm: up to 3.0 L/h
- Ø 1.6 × 1.6 mm: up to 0.45 L/h (450 mL/h)

Inconsistent setting with the installed tube results in dosing errors.

In the solenoid version, these two options are:

CC/STROKE: Dosage in milliliters (cc) per stroke (capacity of approximately 10 L/h).

Capacity: Pump flow rate calculated by multiplying the dosage expressed in milliliters per stroke by the maximum number of strokes (180) of the pump, relative to 60 minutes of operation.

MODE

Allows you to define the operating mode of Pump 1. The available options are:

DISABLED. The pump is disabled and does not perform any dosing operation.

BIOCIDE. The pump operates as a biocide dosing pump.
Selecting this mode enters the Biocide configuration submenu. (see PUMP 1)

INHIBITOR. The pump operates as an inhibitor dosing pump.
Selecting this mode takes you to the Inhibitor submenu.

INHIBITOR MENU (PUMP 2 ONLY)

This submenu allows configuration of the dosage of the inhibitor associated with Pump 2.

FEED MODE.

The FEED MODE parameter defines the control logic of inhibitor dosing.

The available options are:

- Water Meter
- Water Meter PPM (WM PPM)
- % Time
- % Bleed

Selection of the Feed Mode changes the menu items available in the Inhibitor submenu.

9.6 "WT" Main Menu, operating mode pump 2



FEED MODE = Water Meter

When the Water Meter mode is selected, the inhibitor dosage is activated according to the pulses from the water meter.

The following settings are available:

- Number of water meter pulses
- Dosing time Minutes (m) Seconds (s)
- RPM Pump rotation speed
- FLOW (STOP / NO)

The operation and parameter format are similar to those used for biocide dosing.

Number of water meter pulses

Defines the number of pulses from the water meter required to trigger an inhibitor dosing event.

The value should be consistent with the characteristics of the installed meter (pulses per liter or per cubic meter).

Dosing time

Defines the duration of dosing that is performed when the set number of pulses is reached.

The dosing time is expressed by two separate parameters:

- Minutes (m) Sets the number of minutes of pump operation.
- Seconds (s) Sets the number of seconds of pump operation.

The total dosing time is given by the sum of the minutes and seconds set.

RPM (peristaltic version, max. 100 rpm)

Sets the rotation speed of the peristaltic pump motor during dosing. The value of RPM directly affects the effective flow rate of the dosed product.

SPM (Electromagnetic version, max 180 per minute)

Sets the maximum number of strokes per minute. The SPM value directly affects the actual flow rate of the dosed product.

9.7 "WT" Main Menu, operating mode pump 2



FEED MODE = WM PPM (Water Meter PPM).

When WM PPM mode is selected, inhibitor dosing is managed to maintain a proportional concentration (ppm) according to the volume of water transited.

In this mode, the configuration items change as follows:

- PPM Target concentration value to be maintained
- RPM Pump rotation speed
- Concentration (%) Percentage concentration of the chemical used

PPM

Set the target concentration value, expressed in ppm (parts per million), for the system to maintain in the plant water. The value entered represents the desired concentration of active ingredient in relation to the volume of water measured by the meter.

RPM (peristaltic version, max. 100 rpm)

Sets the rotation speed of the peristaltic pump during inhibitor dosing. The RPM value determines the actual pump flow rate as a function of the installed tubing and is used by the system to calculate the volume of dosed product.

SPM (Electromagnetic version, max 180 per minute)

Sets the maximum number of strokes per minute. The SPM value directly affects the actual flow rate of the dosed product.

CONCENTRATION (%)

Set the concentration of the chemical used, expressed as a percentage (%). The value represents the percentage of active ingredient contained in the inhibitor product and is used by the system to convert the set ppm value to the volume of product to be dosed. Setting the product concentration correctly is critical to ensure compliant dosing.

In **WM PPM** mode, no fixed dosing time is set; dosing is automatically calculated according:

- To water meter pulses,
- To the set ppm value,
- To the concentration of the product,
- To the flow rate resulting from the RPM speed.

Important Operational Note

- Selection of the WM PPM mode requires the correct concentration setting Of the chemical.
- Incorrect ppm values or concentration may result in noncompliant dosages.
- Consistency between water meter, RPM, and product concentration is the responsibility Of the user.

Functional Safety Note

Changing the Feed Mode changes the dosing logic of the inhibitor. Before confirming the configuration, check that the selected mode is consistent with the plant's treatment strategy.

9.8 "WT" Main Menu, operating mode pump 2



FEED MODE = %Time

The %Time mode allows dosing of the inhibitor based on a timed cycle of work and pause, independent of the water meter and purge. Dosing is done according to a percentage of active time within a defined cycle.

In this mode, the configuration items change as follows:

- CYCLE TIME total wash cycle duration in hh mm (hours minutes)
- RPM Pump rotation speed
- % Percentage of dosing time within the cycle.

CYCLE TIME.

Sets the total duration of the dosing cycle. Format: hours (hh) and minutes (mm) The cycle consists of a phase of: dosage (ON) and pause (OFF)

RPM (peristaltic version, max. 100 rpm)

Sets the rotation speed of the peristaltic pump during inhibitor dosing. The RPM value determines the actual pump flow rate as a function of the installed tubing and is used by the system to calculate the volume of dosed product.

SPM (Electromagnetic version, max 180 per minute)

Sets the maximum number of strokes per minute. The SPM value directly affects the actual flow rate of the dosed product.

(%)

Sets the percentage of dosing time within the cycle. The value represents the ratio of working time to total cycle time. Example: Cycle Time = 01:00 % = 30 → the pump doses for 18 minutes and pauses for 42 minutes.

Important Operational Note

The %Time mode is suitable for applications where dosing must be: continuous in time, independent of water consumption, stable and repetitive.

Functional Safety Note

Before confirming the configuration, check that the selected mode is consistent with the plant's treatment strategy.

9.9 "WT" Main Menu, operating mode pump 2



FEED MODE = %Bleed

The %Bleed mode allows dosing of the inhibitor in proportion to the bleed time. Dosing is performed after the bleed is completed, depending on the percentage set

In this mode, the configuration items change as follows:

- PERCENTAGE
- RPM Pump rotation speed

PERCENTAGE

Sets the percentage of dosing versus purge duration. The value represents the fraction of the purge time during which dosing is carried out. Example: Purging time = 10 minutes - Percentage = 50. At the end of the purge, the pump will dose for 5 minutes.

RPM (peristaltic version, max. 100 rpm)

Sets the rotation speed of the peristaltic pump during inhibitor dosing. The value of RPM determines the effective flow rate of the pump as a function of the installed tubing and is used by the system to calculate the volume of product dosed.

SPM (Electromagnetic version, max 180 per minute)

Sets the maximum number of strokes per minute. The SPM value directly affects the actual flow rate of the dosed product.

Functional Safety Note

Dosing in %Bleed mode occurs only if a purge occurs.

Dosing is performed subsequent to the purge, not at the same time.

The duration of dosing is directly proportional to the detected purge time.

Important Operational Note

The %Time and %Bleed modes: do not use the water meter, do not maintain a ppm concentration, and are based solely on purge time and duration.

10. "WT" Main Menu, operating mode feed table



FEED MODE (Inhibitor) mode comparison.

| FEED mode | Reference variable | It depends on the Water Meter | Depends on the Purging | Dosing logic | When to use it |
|-------------|---------------------------|-------------------------------|------------------------|--|--|
| Water Meter | Water meter pulses | Yes | No | Time-based dosing by volume of water transited | Systems with variable water consumption |
| WM PPM | Water volume + ppm target | Yes | No | Proportional dosing to maintain concentration | When precise chemical control is required |
| %Time | Time | No | No | Timed work/pause cycle | Stable plants with constant consumption |
| %Bleed | Purging time | No | Yes | Dosage proportional to the duration of purging | Towers with discharge-related chemical treatment |

Main parameters by mode

| Mode | Main configurable parameters |
|-------------|--------------------------------|
| Water Meter | Pulses, Dosing Time, RPM, Flow |
| WM PPM | PPM, RPM, concentration (%) |
| %Time | Cycle Time, %, RPM |
| %Bleed | Percentage, RPM |

10.1 "WT" Main Menu, operating mode Bleed



OPERATING MODE → BLEED

The BLEED menu allows configuration of the automatic system bleed function based on the measured conductivity value.

The purpose of the purge function is to:

- Limit the accumulation of dissolved salts;
- Maintain conductivity within design values;
- Ensure the proper chemical balance of the circuit.

SETPOINT

Sets the intervention conductivity value for purge activation.

- Unit of measurement: μS (microSiemens)
- Measurement scale: dependent on the type of conductivity probe installed

When the measured conductivity value exceeds the set setpoint, the system enables the purge function according to the configured parameters. The value set should be consistent with the type of probe and the operating conditions of the system.

SETPOINT DELAY

Sets the time delay between exceeding the setpoint and the actual activation of the purge.

- Unit of measurement: minutes

This function avoids purging interventions caused by transient changes or temporary measurement disturbances.

DEAD BAND.

Sets the hysteresis band of the purge function.

- Unit of measurement: μS (microSiemens)
- Measurement scale: dependent on the type of conductivity probe installed

The purge function is turned off only when the conductivity value falls below the setpoint minus the dead band value. This setting prevents repeated cycles of opening and closing the purge.

TIME LIMIT

Sets the maximum time allowed for the setpoint to be reached during the purge phase.

- Format: hours (hh) and minutes (mm)

If the conductivity value does not fall within the setpoint when the time limit expires:

- an alarm is generated;
- the purge outlet is automatically closed.

This function protects the system from prolonged ineffective purging conditions.

MANUAL BLEED

Allows manual control of the purge function.

The available options are:

- OFF The purge function operates in automatic mode only.
- ON The purge output is activated manually.

In Manual Bleed ON mode, bleeding occurs regardless of the measured conductivity value.

10.2 "WT" Main Menu, operating mode Bleed



Important Operational Note

- The Manual Bleed ON mode should only be used for test operations or maintenance.
- During manual purging, automatic control logics are not applied.
- Incorrect settings of purging parameters may cause excessive consumption Of water or non-compliant operating conditions.

Functional Safety Note

Exceeding the Time Limit generates an alarm condition and stops purging to prevent abnormal operation of the system. Verification of the cause of the abnormality is the responsibility of the user.

BLEED Duty Cycle

| Phase | Condition | System action | Operational Notes |
|-------|--|-------------------------------|----------------------|
| 1 | Conductivity \leq Setpoint | Bleed off | Normal operation |
| 2 | Conductivity $>$ Setpoint | Start counting Setpoint Delay | No active output |
| 3 | Setpoint Delay | Purging activation | Opening BLEED output |
| 4 | Active purging | Conductivity monitoring | System in adjustment |
| 5 | Conductivity \leq (Setpoint - Dead Band) | Deactivating purging | BLEED output closure |
| 6 | Active purging beyond Time Limit | Purge Closure + Alarm | Abnormal condition |
| 7 | Manual Bleed = ON | Forced purging | Ignore conductivity |

Parameter legend

Setpoint: Intervention conductivity value

Setpoint Delay: Delay before purge activation

Dead Band: Bleed-off hysteresis

Time Limit: Maximum allowed purge time

Manual Bleed: Manual bleed control

10.3 "WT" Main Menu, Alarms and Warnings.



DEVICE MENU → ALARMS AND WARNINGS

The Alarms and Warnings menu allows configuration of alarm and warning (warning) conditions generated by the controller based on the states of inputs, outputs and process parameters.

The menu is divided into the following submenus:

- Inputs / Outputs
- Others

INPUTS / OUTPUTS

This submenu allows configuration of alarms associated with digital inputs and system outputs.

BIOCIDIC LEVEL

Allows management of biocide low level alarm.

The following settings are available:

- Contact. Type of level sensor contact: NO (Normally Open) - NC (Normally Closed)
- Delay. Alarm tripping delay, expressed in seconds.
- Reserve. Residual amount of product, expressed in liters, before the activation of the alarm of PRODUCT END.

INHIBITOR LEVEL

Allows management of the low-level inhibitor alarm.

The following settings are available:

- Contact. Type of level sensor contact: NO (Normally Open) - NC (Normally Closed)
- Delay. Alarm tripping delay, expressed in seconds.
- Reserve. Residual amount of product, expressed in liters, before the activation of the alarm of PRODUCT END.

FLOW SENSOR

Allows configuration of the input associated with the flow sensor.

The following settings are available:

- Contact. Type of level sensor contact: NO (Normally Open) - NC (Normally Closed)
- Delay. Alarm tripping delay, expressed in seconds, before the signaling of no flow.
- NoFlow. System behavior when there is no flow:

STOP - Stops the dispensing functions.

NO STOP - Signaling without stopping functions

10.4 "WT" Main Menu, Alarms and Warnings



STANDBY

Allows configuration of the Standby input, used to bring the controller into a suspended operational state.

The following settings are available:

- Contact. Type of level sensor contact: NO (Normally Open) - NC (Normally Closed)
- Delay. Alarm tripping delay, expressed in seconds.

ALARM OUTPUT

Allows configuration of the relay alarm output by defining:

- Contact. Type of level sensor contact: NO (Normally Open) - NC (Normally Closed)
- What alarm or warning conditions trigger the output.

Enabling events on the alarm output

For each of the following conditions, it is possible to enable or disable the activation of the alarm output by flags:

- **Low Biocide Level Alarm.**
- **Low Biocide Level Warning.**
- **Low Inhibitor Level Alarm**
- **Low Inhibitor Level Warning.**
- **No Flow**
- **No Flow Warning**
- **Standby (waiting)**
- **Bleed Timeout (unloaded timeout)**
- **Bleed Timeout Warning (unloaded timeout)**
- **High Conductivity**
- **High Conductivity Warning**
- **Low Conductivity**
- **Low Conductivity Warning**
- **WMI (pulse lance counter)**
- **WMI Warning (pulse launcher counter)**

If the flag is:

- enabled → the event activates alarm output
- disabled → the event doesn't activate alarm output

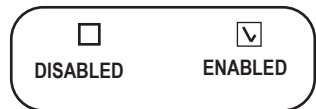

Important Operational Note

- Alarms indicate critical conditions that may affect plant operation.
- Warnings indicate abnormal conditions that are not critical but should be monitored.
- The correct configuration of the alarm output is the responsibility of the user.

10.5 "WT" Main Menu, Alarms and Warnings, Others



OTHERS ALARMS

The Others submenu includes additional alarm and warning conditions that are not directly associated with the instrument's physical inputs or outputs. The Others Alarms menu includes the following alarm conditions:

- **LOC (Low Conductivity) – Low conductivity alarm**
- **HIC (High Conductivity) – High conductivity alarm**
- **Water Meter**
- **BLT (Bleed Timeout)**

For LOC and HIC, in addition to selecting ON or OFF, it is possible to choose the threshold management mode.

ABS (Absolute)

In ABS mode, the alarm threshold is a fixed value manually configured by the user.

The alarm is triggered when: conductivity falls below the configured LOC value, conductivity exceeds the configured HIC value. The thresholds are independent of the control setpoint.

Example (ABS)

Control setpoint = 2000 μ S

LOC (ABS) = 800 μ S | HIC (ABS) = 2500 μ S

If conductivity drops to 750 μ S → LOC alarm is triggered

If conductivity rises to 2600 μ S → HIC alarm is triggered

Even if the setpoint is modified, the alarm limits remain at 800 and 2500 μ S.

TRK (Tracking)

In TRACK mode, alarm thresholds are calculated relative to the control setpoint.

The limits are defined as: LOC = Setpoint – Delta, HIC = Setpoint + Delta

If the setpoint changes, the alarm thresholds automatically adjust.

Example (TRACK)

Setpoint = 2000 μ S | Delta = 200 μ S

LOC = 1800 μ S | HIC = 2200 μ S

If conductivity drops to 1750 μ S → LOC alarm is triggered

If conductivity rises to 2250 μ S → HIC alarm is triggered

If the setpoint is changed to 2200 μ S:

New limits:

LOC = 2000 μ S | HIC = 2400 μ S

No manual adjustment of the alarm thresholds is required.

BLT (Bleed Timeout)

This function defines the system behavior when the maximum bleed time is exceeded.

The available options are:

STOP BLEED. In case of Bleed Timeout, the bleed operation is stopped and the corresponding alarm or warning condition is generated.

NO STOP BLEED. In case of Bleed Timeout, the bleed operation continues and only the alarm notification is generated. This setting directly affects system safety and overall water consumption of the installation.

10.6 "WT" Main Menu, Alarms and Warnings, Others



WM (Water Meter)

Allows management of anomaly conditions related to the water meter. The following settings are available: ON / OFF

Enables or disables monitoring of the Water Meter: STOP / NO STOP

pstDefines the behavior of the system in case of a meter failure:

- STOP - Stops associated functions
- NO STOP - Generates only signaling
- Time (h:mm)

Sets the maximum time allowed without pulse from the water meter before the alarm or warning is generated.

Important Operational Note

The LOC, HIC, BLT and WM functions directly influence the behavior of the system under abnormal conditions.

Enabling or disabling these functions must be consistent with the plant management strategy.

The reporting of alarms and warnings is dependent on the configuration of the Alarm Output.

Functional Safety Note

Disabling monitoring functions may reduce the level of protection of the system.

Responsibility for configuration rests with the user.

Alarms and Warnings - Effects on the system

| Event | Type | Signaling | Stop Functions | Alarm Output Activation | Threshold Mode |
|---------------------|---------|-----------|---------------------------|-------------------------|----------------|
| High Conductivity | Alarm | Yes | Yes | If enabled | ABS / TRK |
| High Conductivity | Warning | Yes | No | If enabled | ABS / TRK |
| Low Conductivity | Alarm | Yes | Yes | If enabled | ABS / TRK |
| Low Conductivity | Warning | Yes | No | If enabled | ABS / TRK |
| Low Biocide Level | Alarm | Yes | Yes | If enabled | — |
| Low Biocide Level | Warning | Yes | No | If enabled | — |
| Low Inhibitor Level | Alarm | Yes | Yes | If enabled | — |
| Low Inhibitor Level | Warning | Yes | No | If enabled | — |
| No Flow | Alarm | Yes | Yes (if NoFlow = STOP) | If enabled | — |
| No Flow | Warning | Yes | No | If enabled | — |
| Standby | Alarm | Yes | Yes | If enabled | — |
| Bleed Timeout | Alarm | Yes | Yes (if BLT = STOP BLEED) | If enabled | — |
| Bleed Timeout | Warning | Yes | No | If enabled | — |
| WMI (Water Meter) | Alarm | Yes | Yes (if WM = STOP) | If enabled | — |
| WMI (Water Meter) | Warning | Yes | No | If enabled | — |

Note for LOC and HIC:

When ABS is selected, alarm thresholds are fixed values manually configured. When TRK is selected, alarm thresholds dynamically follow the conductivity control setpoint:

LOC = Setpoint – Delta

HIC = Setpoint + Delta

The selected threshold mode does not change the system reaction (Alarm vs Warning), but only the calculation of the triggering limits.

Legend

Alarm: critical condition that may affect the operation of the system

Warning: non-critical abnormal condition

If enabled: the event activates the alarm output only if the corresponding flag is set to ON

Stop functions: stop the dosing and/or purging functions according to the configuration

Operational Note

The final behavior of the system depends on the combination of: individual event configuration, settings in the Inputs / Outputs and Others menus, alarm output configuration.

11. "WT" Main Menu, Communication



The Modbus RS485 menu allows configuration of serial communication parameters for integrating the controller with supervisory systems, PLCs or external control devices. Use the RS485 output (B) for hardware connection.

What is Modbus RS485

Modbus is a standard industrial communication protocol widely used for data exchange between electronic devices in the industrial environment.

Communication takes place over the RS485 interface, which allows:

- connections over long distances,
- multi-device communication on a single line,
- high reliability in industrial environments.

The controller operates as a Modbus RTU slave device.

Configuration parameters

To ensure proper communication, the parameters configured on the controller must exactly match those of the master system (PLC or supervisor).

MODBUS ID

Sets the Modbus address of the device on the communication line.

- Function: uniquely identifies the controller within the RS485 network
- Allowed value: numeric
- Note: each device connected on the same line must have a different Modbus ID

BAUD RATE

Sets the serial communication speed. The value must be the same on all devices connected to the line. A higher Baud Rate enables faster communication, but may reduce reliability on long or disturbed lines.

FORMAT

Defines the format of serial data, namely: number of data bits, parity, number of stop bits.

The following options are available:

- 8N1 8 data bits, no parity, 1 stop bit
- 8O1 8 data bits, odd parity (Odd), 1 stop bit
- 8E1 8 data bits, even parity (Even), 1 stop bit
- 8N2 8 data bits, no parity, 2 stop bits

Important Operational Note

The Modbus ID, Baud Rate and Format parameters must be identical to those set on the master device. Inconsistent parameters prevent communication. After changing the communication parameters, it may be necessary to restart communication from the master system.

Functional Safety Note

Incorrect configuration of communication parameters may cause: loss of data, failure to acquire measurements, no remote commands. The responsibility for the correct configuration of the Modbus network lies with the user.

12. "WT" Main Menu, Network setup



The Network Setup allows configuration of the network parameters required to connect the WT controller to a local area network (LAN) and enable its IP network communication functions.

Configuration parameters:

IP MODE

Defines how the IP address is assigned to the controller.

- Dynamic (DHCP)

The IP address is automatically assigned by the router or DHCP server in the network.

- Static

The IP address is set manually by the user. In Static mode, all network parameters must be configured correctly.

IP ADDRESS

Sets the IP address of the controller within the local network. This parameter is only available if IP MODE = Static. The address must be:

- unique within the network,
- compatible with the configured subnet.

SUBNET MASK

Sets the network mask, used to define the size of the local network. This parameter is only available if IP MODE = Static. The value must be consistent with the LAN configuration.

GATEWAY

Sets the network gateway address, usually coincident with the router. This parameter allows the controller to communicate with devices outside the local network.

DNS

Sets the address of the DNS server, used for domain name resolution.

This parameter is needed for: remote connectivity services, communications to external servers.

SAVE

Allows you to save or cancel entered network settings.

- YES Saves the configured parameters and makes them operational.
- NO Cancels changes and retains previous settings.

Changes to network parameters become effective only after saving.

Important Operating Note

In case of incorrect manual configuration, the controller may be unreachable on the network. Dynamic (DHCP) mode is recommended if you do not have complete network information. Network configuration must be performed by qualified personnel.

13. "WT" Main Menu, Service



DEVICE MENU → SERVICE

The Service menu provides access to maintenance, log management, access security, and system recovery functions.

The operations available in this menu can affect the overall behavior of the controller and should only be performed by qualified personnel.

LOG SETUP

Allows configuration of the logging system (log) of events and operational data.

The following settings are available:

Active

ON - Enable log logging | OFF - Disable log logging

Time

Sets the reference time for generating reports or timed records.

Every

Defines the frequency of logging or log generation, based on the time unit provided by the system.

Report

Enables or disables the generation of reports based on recorded logs.

Output

Defines the output channel used for log management or export, depending on the interfaces available on the device.

Operational Note

The log system is intended for: operation analysis, maintenance activities, diagnostic support.

MAINTENANCE

Allows management of scheduled maintenance functions of peristaltic pumps.

Biocide Hose Reset

Resets the maintenance counter of the biocide pump hose.

This operation should be performed only after the actual replacement of the hose.

Reset Inhibitor Hose

Resets the maintenance counter of the inhibitor pump hose.

Again, this reset should only be performed following maintenance work.

Safety Note

Resetting the maintenance counters without replacing components may cause: unmonitored wear, loss of dosing reliability.

13.1 "WT" Main Menu, Service



PASSWORD

Allows management of passwords for access to protected menus.

Device Passcode

Sets the numeric password for Device Menu access.

Probe Passcode

Sets the numeric password for access to the Probe Menu.

Operational Note

It is recommended to change the default passwords (0000) to prevent unauthorized access.

POWER DELAY

Sets the start-up delay of the controller after power is supplied.

Unit of measurement: minutes

This function allows you to: avoid simultaneous start-ups with other devices, stabilize the system before activation of the dosing and control functions.

FACTORY DEFAULT

Allows resetting the controller to factory settings.

YES - Performs full reset | NO - Cancels the operation

Restoring to factory settings results in the loss of all custom configurations.

Functional Safety Note

The Factory Default command should be used only when necessary, after checking for operational consequences. The manufacturer is not responsible for configurations lost as a result of voluntary restoration.

14. "WT" Main Menu, Settings



DEVICE MENU → SETTINGS

The Settings menu allows configuration of general system settings, relating to language, date and time, units of measurement, and parameter display mode. The settings defined in this menu affect the display and interpretation of data on the entire controller.

LANGUAGE

Allows selection of user interface language.

The selected language is applied to: menus, messages, alarms and warnings.

DATE AND TIME.

Allows the setting of the system date and time.

Date and time are used for: logging, time schedules, event tracking.

UNIT OF MEASURE

Allows selection of the unit system used by the controller. Two options are available:

- IS (International System)
- US (Imperial System)

Selecting the unit system automatically updates all associated quantities.

VOLUME

Units of volume measurement:

- IS: liters (L)
- US: gallons (gal)

TEMPERATURES

Units of temperature measurement:

- IS: degrees Celsius (°C)
- US: degrees Fahrenheit (°F)

DATE

Date display format, consistent with the selected unit system.

TIME

Time display format, consistent with the selected unit system.

CONDUCTIVITY

Allows selection of the unit of measurement of the displayed conductivity.

The following options are available:

- μ S (microSiemens)
- PPM (parts per million)

Changing the conductivity unit only affects the value display, not the signal measured by the probe.

DISPLAY

Allows adjustment of screen contrast to improve data display.

Important Operational Note

Changing the unit system affects all related menu items. It is recommended to check the consistency of set units before configuring setpoints, thresholds and dosing parameters.

Functional Safety Note

The use of units of measure that are inconsistent with plant design values can cause misinterpretations of process parameters. The responsibility for correct configuration rests with the user.

15. "WT" Main Menu, PROBE



MAIN MENU → PROBE

The Probe Menu allows configuration and calibration of the measurement probes connected to the controller.

The menu consists of the following submenus:

- Select Probe
- Calibration μS
- Calibration Temperature
- Correction Factors

The operations available in this menu directly affect the accuracy of measurements and should be performed by qualified personnel.

SELECT PROBE

The Select Probe submenu allows selection of the working scale of the conductivity probe connected to the controller. The selected scale defines the operating measurement range of the probe and must be consistent with the installed probe model.

Available measurement scales for ECD probe: 0 / 10000 μS . Measurement scales available for ECDIND probe: 0 / 3000 μS , 0 / 30000 μS .

Scale selection determines: conductivity display range, measurement resolution, correct interpretation of probe signals.

Basic Operating Note

Selection of the working scale must be made before performing any operation of: calibration, setting correction factors, configuring conductivity setpoints.

Functional Safety Note

The controller cannot automatically detect an incorrect measurement scale. The responsibility for the correct selection of the working scale according to the installed probe lies with the user.

CALIBRATION μS

(Conductivity Probe Calibration). This submenu allows calibration of the conductivity probe using a two-point procedure. Proper calibration of the probe is essential to ensure reliable measurements and proper control of purging and dosing.

| | |
|---------------------------|--------------------------------------|
| Calibration μS | |
| FS | Full Scale |
| P1 | 3000 μS |
| P2 | |
| Full Scale | ESC OK |

| | | |
|---------------------------|---------------------|--------------|
| Calibration μS | | |
| P1 | $\mu\text{S PROBE}$ | Calib At |
| P2 | 0000 | 10.00 |
| TE | | |
| 2nd Point | ESC OK | |

| | |
|---------------------------|----------------|
| Calibration μS | |
| TE | Comp Automatic |
| CA | Disable |
| Ex | |
| Comp Auto | ESC OK |

Conductivity calibration procedure

The conductivity calibration procedure involves a zero calibration (P1) and a second calibration point (P2) that requires the use of a buffer solution with a value close to the working range. In addition, the TE (Temperature) and CA (Automatic Compensation) parameters must be set.

Note: This procedure assumes that the instrument is properly installed, correctly configured, and connected to a functioning probe. Calibration must be performed at the actual system operating temperature; otherwise, inaccurate results may occur. In case of error, the instrument will display the message "REMAKE CALIBRATION" or prompt the user to restore the calibration values to the default settings.

15.1 "WT" Main Menu, PROBE



P1 and P2

During this procedure, the probe must be dry, clean and not installed in the system.

- Set the knob to P1 and press.
- Move the cursor to OK and press the knob again.
- Set the knob to P2 and press to enter the second point calibration submenu.
- Prepare the buffer solution and immerse the probe sensor in the solution.
- Wait until the displayed value is stable, and according to the value of the buffer solution, turn the knob until the displayed value matches that of the solution ("Calib At" field).
End the procedure by moving the cursor to OK.

TE and CA

Conductivity measurements are temperature dependent. The degree of influence of temperature on conductivity varies with the solution and can be calculated by the following formula:

$$C_{25} = C / \{1 + [a / 100 (t - 25)]\}$$

where:

C₂₅ = conductivity of the solution at 25 °C

C = conductivity at the operating temperature

a = temperature coefficient of the solution (%/°C)

| Probe read value (uS or ppm) | Alpha (a) | Temperature (°C / °F) | Displayed Value (us or ppm) |
|---------------------------------|-----------|--------------------------|--------------------------------|
| 5227 | 1.2 | 35°C / 95°F | 4934 |
| 4524 | 3.5 | 27°C / 80.6°F | 4228 |
| 3924 | 2.1 | 40°C / 104°F | 2984 |

Some example values of the coefficient alpha (a) are given in the table above. To determine the value of "a" for other solutions, simply measure conductivity at different temperatures and graph the change in conductivity as a function of temperature change.

Temperature Compensation

Allows you to define the temperature compensation mode of the conductivity measurement.

The following options are available: Automatic or Manual

Automatic Compensation

In Automatic mode, the system uses the temperature probe measurement to automatically compensate conductivity according to temperature variation. This mode is recommended for most applications.

Manual compensation

In Manual mode, the reference temperature is entered manually by the operator. This mode should be used only under special conditions, such as when there is no reliable temperature measurement.

Technical note - Temperature compensation

The conductivity of water varies with temperature. Compensation allows the measured value to be restored to a reference temperature, making values comparable and stable over time.

15.2 "WT" Main Menu, PROBE



CALIBRATION TEMPERATURE

(Temperature probe calibration)

This submenu allows calibration of the temperature probe. Calibration is done by comparing the measurement of the controller with a reference thermometer.

Calib. AT

Set in the Calib field. AT the temperature value of the system detected with the reference thermometer. The system uses this value to correct the temperature probe reading. Use only reliable and calibrated measuring controllers.

CORRECTION FACTORS

The Correction Factors submenu allows you to optimize the behavior of the measurement according to the operating conditions of the plant.

TAU

Sets the filtering factor (time constant) of the measurement.

The TAU parameter allows you to:

- stabilize reading,
- Reduce fluctuations due to disturbances or rapid changes.

A higher value increases the stability of the measurement but reduces the speed of response.

TEMP COEFF (%)

Set the temperature coefficient, expressed as a percentage (%). This parameter defines how much conductivity varies with temperature and is used for thermal compensation of the measurement. The value should be consistent with the characteristics of the treated water.

Important Operational Note

Probe calibration should be performed periodically. Incorrect calibration values or correction factors compromise purging and dosing control. After each calibration, check the consistency of readings under actual operating conditions.

Functional Safety Note

The controller cannot automatically detect incorrect calibrations. The responsibility for correct calibration of probes lies with the user.

Appendix. A - Replacement of Peristaltic Tube

Procedure for Replacing the Semi-Assembled Tube + Slide Peristaltic Pump WN

Useful/Necessary Materials

- New semi-assembled tube + sled (Required)
- Compass wrench with $\text{ØD}=4\text{mm}$ and $A=19.7\text{mm}$ (Useful)

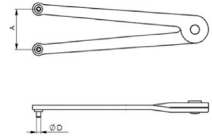

Operational Steps

1. Preparation of the Pump

- Turn off the pump and disconnect it from the power supply to ensure safety.
- Close any delivery and suction valves to prevent fluid spillage.
- Drain any residual fluid in the peristaltic tube.

2. Removal of the Old Semi-Assembled

- Open the pump cover to access the slide and tube.



3. Remove the rotor cover disc



4. Pull out the sled with the worn tube, taking care not to damage the rollers and the pump body



5. Insert and secure the slide with the new tube into the pump Making sure it is properly aligned



Appendix. A - Replacement of peristaltic tube

6. Bring the tube into position by helping with the socket wrench or manually, by rotating the Roller Holder and accompanying the tubing by pressing towards the inside of the Pump Body



7. Check and Test

- Manually rotate the rollers to ensure that the tube is well positioned and running unobstructed

- Replace the Rotor Cover Disk



- Close the pump cover again

- Turn the power supply back on and start the pump for a no-load test



Caution: When removing the roller carrier, always verify that, during reassembly, the "A" marking is oriented toward the operator.



Appendix B - Probe Modules

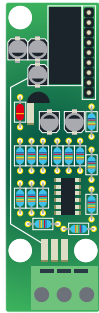

01|02|03

ECDC

- N/A → 01 (GND)
- → 02 (POWER)
- → 03 (SIGNAL)

- → TEMPERATURE
-

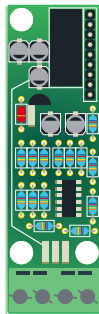

01|02|03|04

ECDIND

- N/A → 01 (GND)
- → 02 (GND)
- → 03 (SIGNAL)
- → 04 (POWER)

- → TEMPERATURE
-

Caution: connections must be made only by qualified and trained personnel

Appendix C - DIMENSIONS (mm) - Peristaltic Version

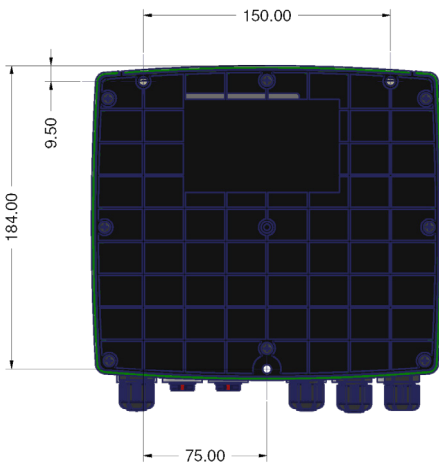
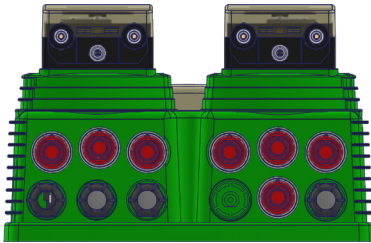
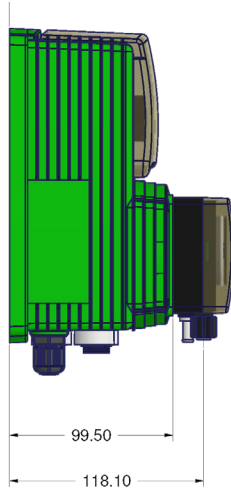
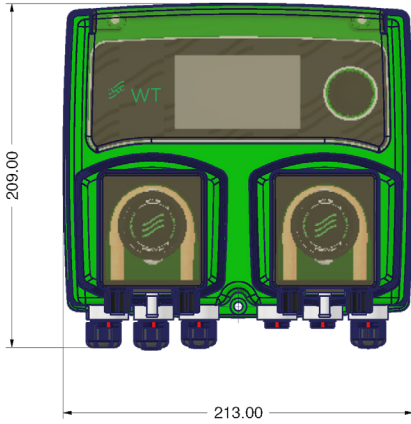

| PERISTALTIC CONSTRUCTION MATERIALS | |
|--|------------|
| ELEMENT | MATERIAL |
| Pump Body | PC / ABS |
| Cover | PC |
| Dust Cover Bushing | PEEK / PPS |
| Pipe Stop Hose Hose holder Hose Connector Vent | PVDF |
| Peristaltic Roller | POM DELRIN |
| Peristaltic tube (Long Duration) | TPV |

Appendice C - DIMESIONS (mm) - Electromagnetic Version

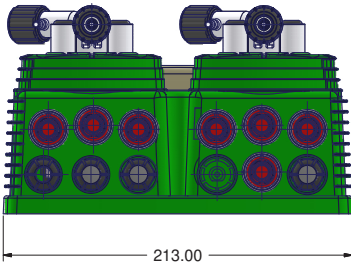
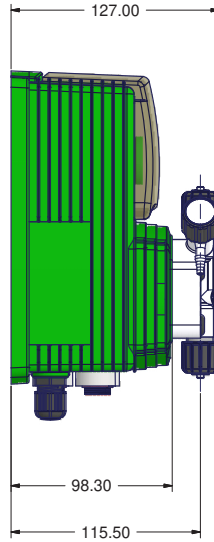
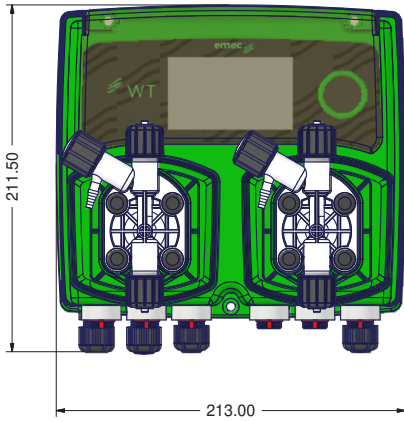

| PUMP HEAD BUILDING MATERIALS | |
|------------------------------|----------------|
| ELEMENT | MATERIAL |
| Pump Head | PP + FV / PVDF |

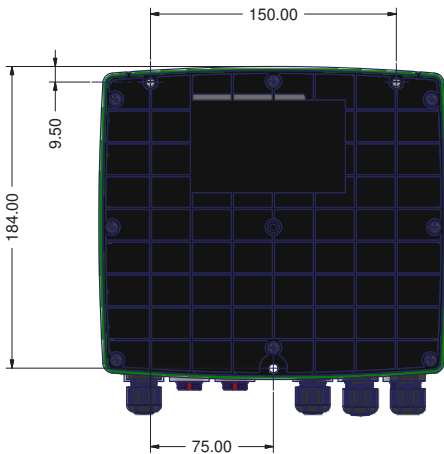

| MAGNETIC DOSING CAPACITY | | | | | | | |
|--------------------------|-----|------|-----------|---------|-----------|--------|----------|
| bar | l/h | cc/s | Injection | Suction | Pump body | Ø mag. | Fittings |
| 7 | 6 | 0,56 | 4x6 | 4x6 | K | 60 | 3/8" |

| PERISTALTIC DOSING CAPACITY / Tube Ø4.8x1.6 | | |
|---|-----------------------------|----------|
| Pressure | Flow range | Speed |
| bar (psi) | l/h (gal/h) | rpm |
| 2 (29) | 0,12 to 12 0,0317 to 3,17 | 1 to 100 |

| PERISTALTIC DOSING CAPACITY / Tube Ø1.6x1.6 | | |
|---|-------------------------------|----------|
| Pressure | Flow range | Speed |
| bar (psi) | l/h (gal/h) | rpm |
| 2 (29) | 0,018 to 1,8 0,0047 to 0,47 | 1 to 100 |

Smaltimento e fine vita.

1. Regulatory Framework

This professional equipment for conductivity control in cooling towers, including integrated dosing pumps, falls within the scope of Directive 2012/19/EU (WEEE) and applicable national implementing legislation. The product complies with CE marking requirements, including Directive 2011/65/EU (RoHS) on the restriction of hazardous substances in electrical and electronic equipment.

For North American markets, the product may be certified according to applicable UL standards. The manufacturer operates under an environmental management system compliant with ISO 14001.

2. Separate Collection Symbol

The crossed-out wheeled bin symbol indicates that the equipment must not be disposed of with unsorted municipal or industrial waste.

3. Responsibilities of the Professional User

At the end of its service life, the equipment must be:

- safely removed from the installation;
- drained from any chemical residues in accordance with environmental regulations;
- classified as professional WEEE;
- delivered to authorized waste management operators.

The holder of the equipment is responsible for ensuring proper waste classification and full traceability in accordance with applicable national legislation.

4. Selective Treatment

Before disposal, the following components must be removed and treated separately:

- electronic boards and control modules;
- components containing potentially hazardous substances;
- batteries or accumulators (if present);
- parts contaminated by process chemicals.

All operations must be performed by qualified personnel.

5. Extra-EU Markets

For installations outside the European Union, disposal must comply with the environmental regulations in force in the country of installation.

The manufacturer assumes no responsibility for end-of-life management not performed in accordance with applicable local legislation.

- Directive 2012/19/EU – Waste Electrical and Electronic Equipment (WEEE)
- Directive 2008/98/EC – Waste Framework Directive
- Directive 2011/65/EU and subsequent amendments – RoHS
- Regulation (EU) 2019/1020 – Market Surveillance (where applicable)
- National implementing legislation (e.g. Legislative Decree 49/2014 – Italy, where applicable)
- Applicable national regulations in the country of installation (for extra-EU markets)

Analytical Index (alphabetical)

| | |
|---|------------|
| Alarm | 7, 24–27 |
| Alarm Output | 25 |
| Alpha (Temperature Coefficient a) | 34 |
| APP Notification | 12 |
| Baud Rate | 28 |
| BIO1 (Biocide 1 Counter) | 10 |
| BIO2 (Biocide 2 Counter) | 10 |
| Biocide (Pump 1 Mode) | 14–15 |
| Bleed (Automatic Purge) | 22–23 |
| Bleed Timeout (BLT) | 22, 26 |
| Blow Down | 6 |
| Correction Factors | 35 |
| Cycle Time (%Time Mode) | 19 |
| Dead Band | 22 |
| DHCP | 29 |
| Display Settings | 32 |
| Drift | 6 |
| Encoder | 3 |
| Factory Default | 31 |
| Feed Mode (Inhibitor) | 16–21 |
| Flow Sensor | 24 |
| Gateway | 29 |
| High Conductivity (HIC) | 26 |
| Hose (Peristaltic Tube) | 14, 36–37 |
| Inhibitor (Pump 2 Mode) | 16–20 |
| IP Address | 29 |
| IP Mode (Dynamic / Static) | 29 |
| Log Setup | 30 |
| Low Conductivity (LOC) | 26 |
| Manual Bleed | 22–23 |
| Manual Menu | 8–9 |
| Modbus ID | 28 |
| Modbus RS485 | 28 |
| Network Setup | 29 |
| PPM (Parts per Million) | 18, 32 |
| Power Delay | 31 |
| Probe Calibration | 33–35 |
| RPM | 15, 17–20 |
| RS485 | 28 |
| Setpoint (Conductivity) | 22 |
| Setpoint Delay | 22 |
| Standby | 25 |
| Statistics | 10 |
| Subnet Mask | 29 |
| TAU | 35 |
| Temperature Compensation | 34 |
| Temp Coeff (%) | 35 |
| Time Limit | 22 |
| Unit of Measure (IS / US) | 32 |
| Unloading..... | 8 |
| Water Meter (WM) | 10, 14, 17 |
| WM PPM | 18 |
| Warning | 7, 24–27 |

General INDEX.

| | | |
|------|---|------------|
| 1. | Safety Information and EC Rules | pag. 1–2 |
| 2. | Introduction to WT System | pag. 3 |
| 3. | User Interface and Encoder | pag. 3 |
| 4. | Electrical Connections and I/O Configuration | pag. 4 |
| 5. | Cooling Towers – Operating Principles | pag. 5–6 |
| 6. | Main Screen and Operating Status Messages | pag. 7 |
| 7. | Manual Mode (Manual Menu) | pag. 8–9 |
| 8. | Statistics and Cumulative Counters | pag. 10 |
| 9. | Main Menu – Protected Access | pag. 11 |
| 10. | Device Menu | pag. 12–32 |
| | | |
| 10.1 | Operating Mode (Pump 1, Pump 2, Bleed, Water Meter) | |
| 10.2 | Alarms and Warnings | |
| 10.3 | Communication (Modbus RS485) | |
| 10.4 | Connectivity / Network Setup | |
| 10.5 | Service | |
| 10.6 | Settings | |
| | | |
| 11. | Probe Menu (Measurement Configuration) | pag. 33–35 |
| | | |
| 11.1 | Select Probe | |
| 11.2 | Calibration μS | |
| 11.3 | Calibration Temperature | |
| 11.4 | Correction Factors | |
| | | |
| 12. | Appendix | pag. 36–44 |
| | | |
| 12.1 | Peristaltic Tube Replacement | |
| 12.2 | Probe Modules Connections | |
| 12.3 | Dimensions and Construction Materials | |
| 12.4 | Disposal and End of Life | |

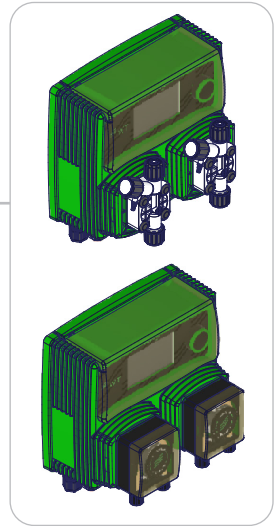

*When disposing of this product, separate the types of materials and send them according to local disposal and recycling requirements.
We appreciate your efforts in supporting the local environmental recycling program.
Working together we will form an active union to ensure that the Planet's priceless resources are preserved.*